

SECTION A-A

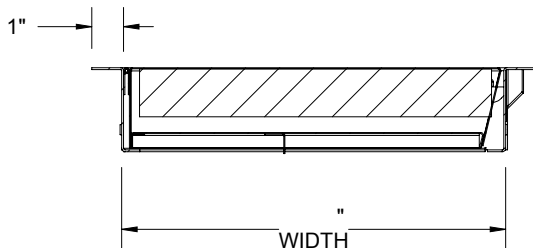
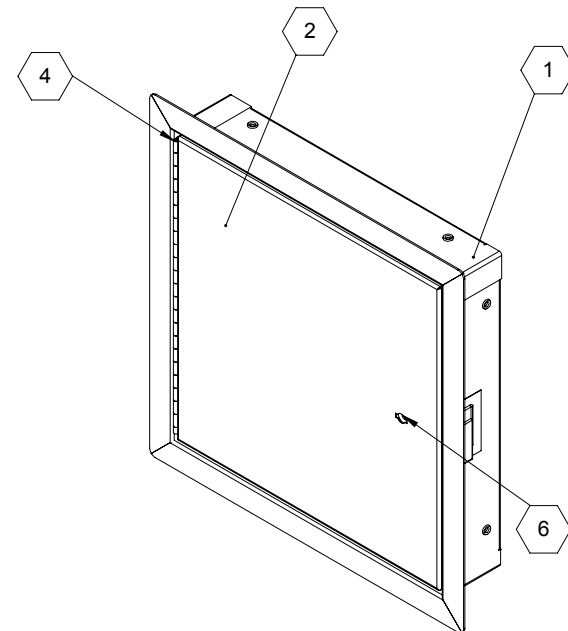

SECTION B-B

ROUGH OPENING: " X " X "  
 CLEAR OPENING: " X " X "  
 DEGREE OF OPENING: 125°

**HORIZONTAL**  
 1 HR WOOD-FRAME CONSTRUCTION  
 3 HR NON-COMBUSTABLE CONSTRUCTION  
**ON SIZES UP TO AND INCLUDING**  
**24" W X 36" H**

**VERTICAL**  
 1-1/2 HOUR "B" LABEL

NOTES:

- ① **FRAME:**
- ② **DOOR:**
- ③ **FINISH:**
- ④ **HINGE:**
- ⑤ **SECONDARY LATCH:**
- ⑥ **LOCK:** KNURLED KNOB/KEYED SLAM LATCH
- ⑦ **INSULATION:** 2" Thick Fire Rated Mineral Wool, 8 R-Value



C **UL** US  
 LISTED

PROJECT:			
ARCHITECT:			
CONTRACTOR:			
QTY:			
PART#:			
 TRI-BUILT® MATERIALS GROUP, LLC		TITLE:	
NAME	DATE	SIZE	DWG. NO.
DRAWN	GML 6/10/2014	A	ITK Shp Dr
RELEASED	DWO TODAY	WEIGHT: 10.2	REV -

B

B

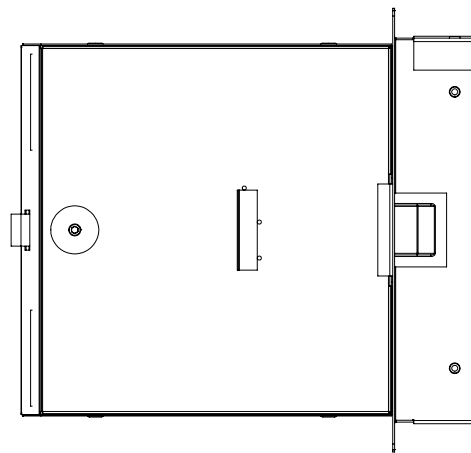
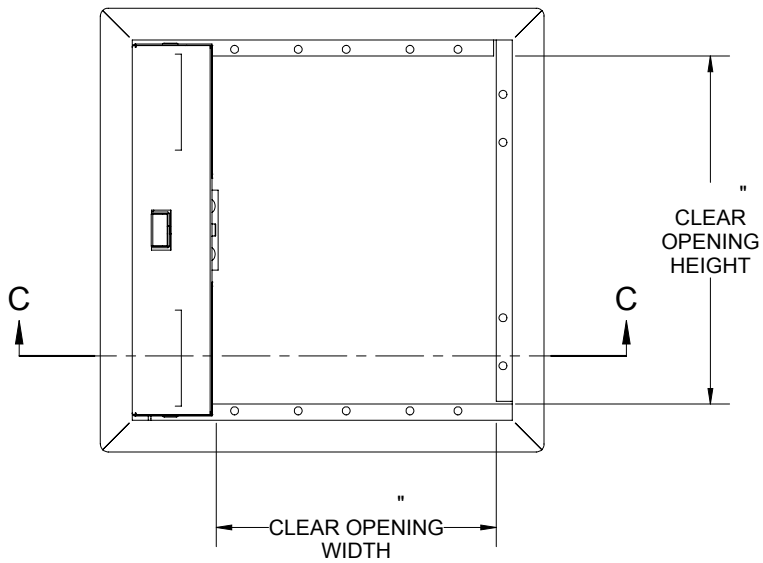

A

A

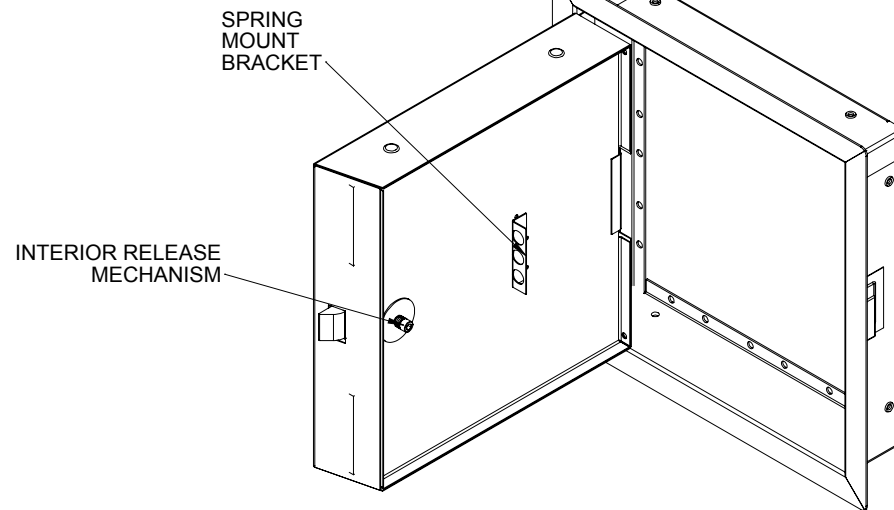
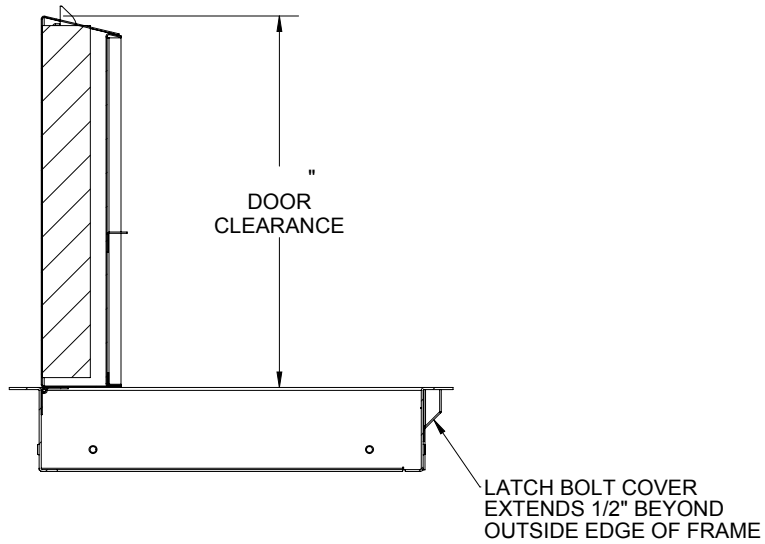

PART#:				TITLE:			
DRAWN	GML	6/10/2014	A	BITK ShpDr		-	
RELEASED	DWO	TODAY	WEIGHT: 10.2		SHEET 2 OF 2		